

Hassco Vertical Storage Tanks Double-Wall

1. Emergency Vent
2. 2" Threaded Fitting
3. 2" Vent
4. ULC Label
5. Vacuum Gauge

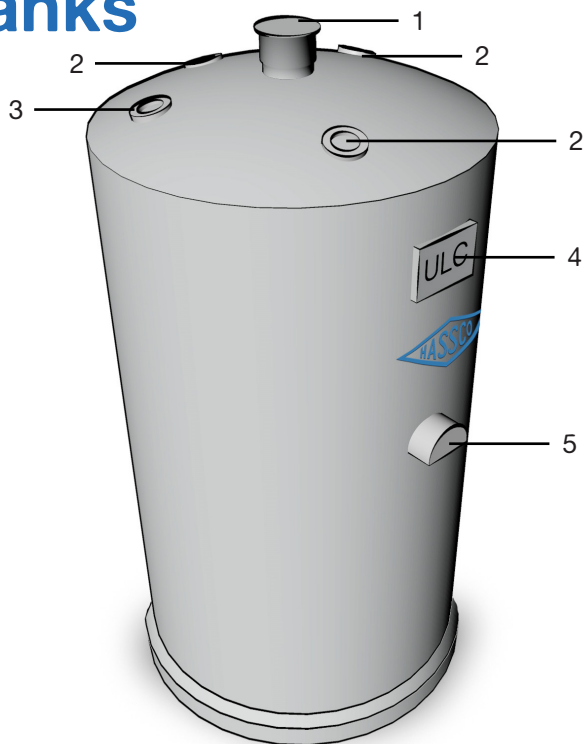

Material (gauge)	Capacity	Diameter	Height	Weight
12	1100L/250G	38"	60"	700lbs.
12	1360L/300G	38"	72"	750lbs.
12	2200L/500G	50"	72"	1100lbs.
12	4500L/1000G	60"	96"	2200lbs.

General Information

HASSCO's Double-Wall ULC approved vertical tanks are an industry proven, cost effective way to store various fuels. Best suited for applications where space might be an issue, these tanks come with threaded fittings for your connections. All HASSCO tanks are phosphate washed prior to applying a high build metal treatment and two top coats of enviro-smart water based paint. Other coating options such as epoxy and powder coatings are available upon request.

Options

- Tank gauges, alarms, liners, heaters and pumping systems
- Powder Coating
- Single-Wall version available

Sizing

- Larger sizes available

Conformity

- ULC S601

